

DVS Reclaim Mini

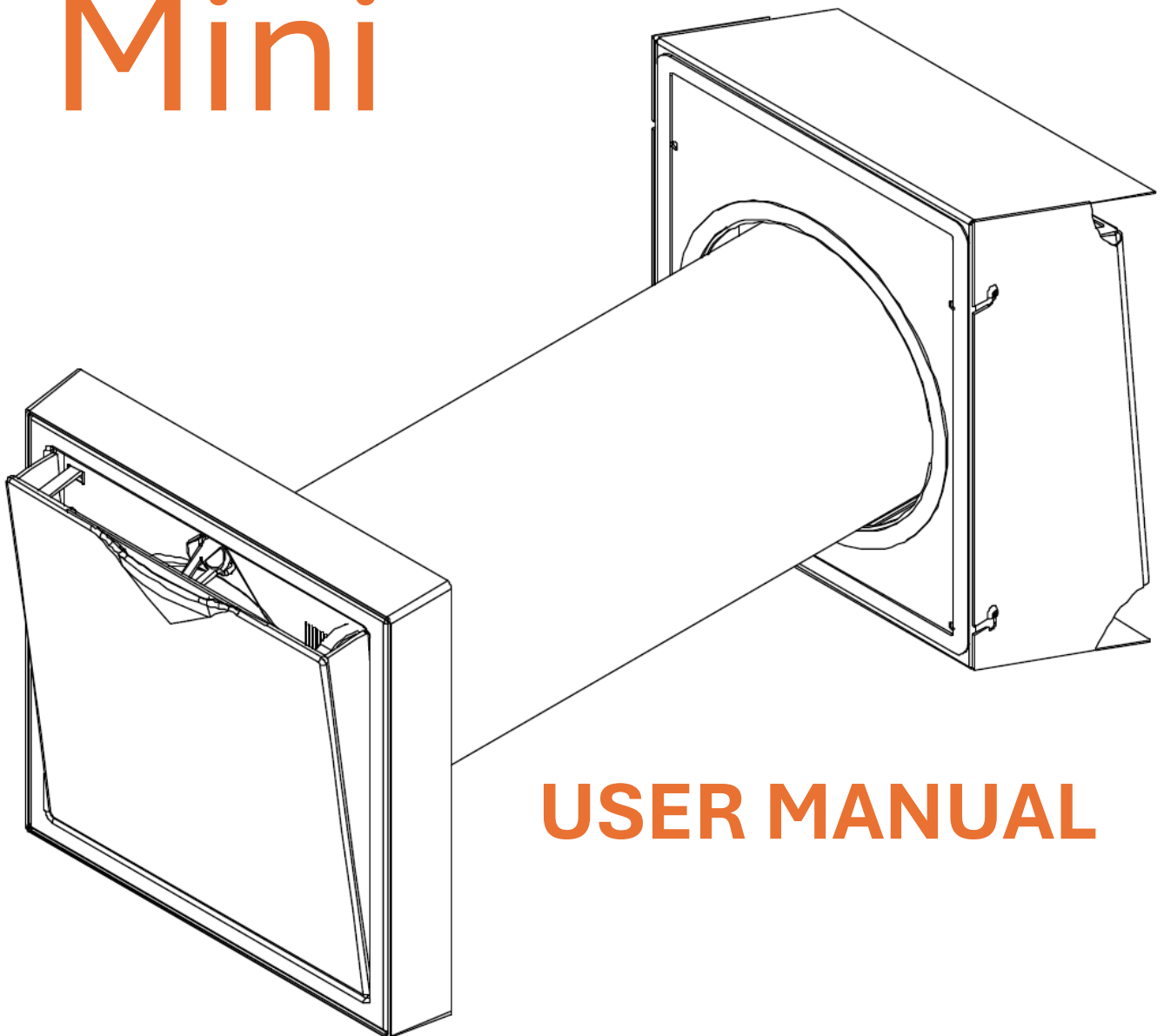

USER MANUAL

DVS HIGH PERFORMANCE: RECLAIM MINI
USER MANUAL

Contents

Understanding Ventilation	2	Changing Device Direction.....	16
Using your DVS Reclaim Mini	2	Setting Up Zones	17
Understanding System Set Up	2	Defining Zone Profiles	17
Ventilation Modes.....	3	Changing the Zone Name.....	18
Zones	3	Changing Humidity and CO2 Limits	
Profiles	4	18
Time-controlled profiles	4	Setting Zone Profile	19
Automatic Profiles.....	6	Scheduling	20
Control Logic	6	Boosting and Pausing	20
Components	7	Wall Controller	21
Inner Panel and Filter.....	7	Zone Navigation	21
Wall Controller (Optional)	7	Setting Zone Fan Speed, Ventilation	
CO2 Sensor including Temperature		Mode and Zone Profile	21
and Humidity (Optional)	9	Pause and Boost	22
Temperature and Humidity Sensor		Troubleshooting	23
(Wireless)	9	Inner Panel Lights.....	23
Programming Your System	10	Wall Controller Events	23
Connecting to the App	10	Resetting	24
First time	10		
When App has been Connected			
Before	11		
Recommended Set-Up	12		
On the App.....	13		
Main Menu.....	13		
Zone View.....	13		
Advanced Settings	13		
Device View	14		
.....	15		
Identifying the Device	15		
Changing Device Zone	15		
Changing Device Name	16		

Understanding Ventilation

Ventilation systems are designed to move air, when we bring fresh air from outside to inside or remove stale air, we are effectively replacing the air in your home with healthier air.

As ventilation for fresh air relies on outside conditions to perform having a solution with sensors allows the system to take additional advantage of the conditions or avoid unfavorable ones (sensors are an optional extra on the Reclaim Mini). Alternatively scheduling of direction, modes and speeds can enhance performance.

The benefits of using fresh outside air for ventilation means we help counteract the pollutants introduced by simply living in our home. However, to get the best out of your ventilation system it's important to reduce as well as refresh.

Some of the key activities to be aware of are:

1. Drying washing inside (including leaving damp towels around the house)
2. Forgetting to run or not leaving the bathroom, kitchen and laundry fans on long enough
3. Not maintaining a healthy indoor temperature (condensation forms when there are cold surfaces and too much moisture)
4. Having moisture in your air source, this is harder to control but adding indoor and outdoor temperature and humidity

sensors means we can automatically respond to unpalatable conditions

Note: *If there is not enough dry air available from your air source (such as in misty, damp and humid climates) then further measures should be taken.*

Ventilation is not the only component of a dry home; it is a critical part of a well-considered solution. Use alongside a good awareness and management of:

- moisture producing activities,
- suitable insulation,
- elimination of thermal bridges and
- sufficient heating

for a comfortable, higher performing, condensation free home.

Using your DVS Reclaim Mini

DVS Reclaim Mini represents our latest in decentralised home ventilation technology. The system is best left to run on its own but for control you may have chosen to add the optional wall controller or work with the built in app control. Both options allow you to see what is happening with your system and to adjust if you need to.

Understanding System Set Up

While your units can be run independently, if you have more than one unit in your home, they need to be introduced to each other and set to operate as best suits the space. This is

DVS HIGH PERFORMANCE: RECLAIM MINI USER MANUAL

typically done at install, the following sections explain different set ups.

Ventilation Modes

The Mini can run in 4 modes: Through Mode (made up of Supply, Extract) and Heat Recovery.



Heat recovery is typically the most efficient as it extracts air you've pre-

warmed or cooled and for 70 seconds stores that energy in the ceramic core, then it reverses the fan and supplies air for 70 seconds the ceramic core releases the stored energy and effectively tempers the incoming air.



Supply brings air in continuously, creating a positive pressure in the

space. This is great when you're trying to keep bad air out and stop infiltration and when your incoming air is of a high quality. It's also the most efficient way to get cooler air into a home when it's more comfortable outside than in.

When equipped with humidity sensors outside and in the summer, profile can automatically trigger this function.



Extract is the opposite of supply; it removes air from a space. Typically used to

quickly remove a contaminant; most



used in bathrooms, kitchens and laundries.



Supplemental units should be installed in bathrooms and kitchens either with or without heat recovery to

deal with moisture at the source.

Through mode, when multiple units are run inside the house some will run predominantly in supply and others will run predominantly in extract, when they're running like this it can be called through mode. **Through mode** captures the way the air moves through the home, entering through one Mini and exiting through another.

In particularly airtight homes it's important to understand the spill pathways of air, when we overflow the house with air in one direction or another, we need to allow that air to escape, it's important to plan these pathways into a design or installation. These pathways often take the form of door under cuts or transfer grilles.

While the system should be left to its own devices most of the time; smart sensors, automations and scheduling can help you get the most of your system.

Zones

After the units are installed and paired, they are grouped together into zones. Your house can be one big zone or multiple zones, and each zone can be programmed with a different ventilation profile. It's best to have an even number of units in each zone so that your house and each zone can remain balanced. In these zones half the units are "supply dominant" and half are "extract dominant" this allows them to always be running in the opposite direction of each other and continuously pulling air through your home.

DVS HIGH PERFORMANCE: RECLAIM MINI USER MANUAL

Within each indoor zone, if demand control is desired, independent CO2 or temperature and humidity sensors should be supplied. Only one outdoor sensor is needed for the entire system. Similarly, only one wall controller is needed for the entire system.

Profiles

Ventilation profiles are assigned to each zone for maximum comfort and demand-driven ventilation. A ventilation profile is a programmable weekly timer which controls three variables:

- Time (7 days, 24 hours each)
- Ventilation level (levels 1 - 4 or pause)
- Ventilation mode (heat recovery or ventilation or pause)

There are two styles of ventilation profile **Time-controlled** and **Automatic**. All ventilation profiles can be adapted to individual requirements. Default profiles, which can be re-programmed and saved according to your individual requirements, are available and allow for maximum individualisation.

Time-controlled profiles

Time-controlled profiles are based on a weekly timer. The fan speed and ventilation mode depend on the day of the week and time of day. In this way, it is possible to set the time and day at which a change of fan speed and/or ventilation mode is to take place to the hour. The time (7 days, 24 h each), the fan speed (levels 1-4) and the ventilation mode (heat recovery, through-

ventilation or pause) are defined for the respective profile.

Sensors integrated into the ventilation zone (e.g. CO2 sensor) have priority over the values stored in the weekly timer. 7 time-controlled ventilation profiles are pre-programmed with different schedules according to working day and weekend:



Bedroom Consideration of falling asleep and sleeping times



Children's room Consideration of children's falling asleep and sleeping times



Bathroom Consideration of times-of-use



Living-room Consideration of times-of-use



Kitchen Consideration of cooking and mealtimes



Holiday mode Basic ventilation when the user is absent

Default schedules for each profile can be found on the next page.

DVS HIGH PERFORMANCE • RFOI AIM MINI

Figure 1 Zone profile default schedules

Bedroom	Children's room	Bathroom	Kitchen	Living room
00:00 - 08:59 Ivl.:1 Mon, Tue, Wed, Thur, Fri	00:00 - 08:59 Ivl.:1 Mon, Tue, Wed, Thur, Fri	00:00 - 06:59 Ivl.:3 Mon, Tue, Wed, Thur, Fri	00:00 - 05:59 Ivl.:3 Mon, Tue, Wed, Thur, Fri	00:00 - 07:59 Ivl.:2 Mon, Tue, Wed, Thur, Fri
09:00 - 10:59 Ivl.:4 Mon, Tue, Wed, Thur, Fri	09:00 - 11:59 Ivl.:4 Mon, Tue, Wed, Thur, Fri	06:00 - 8:59 Ivl.:1 Mon, Tue, Wed, Thur, Fri	06:00 - 09:59 Ivl.:1 Mon, Tue, Wed, Thur, Fri	08:00 - 10:59 Ivl.:4 Mon, Tue, Wed, Thur, Fri
11:00 - 16:59 Ivl.:2 Mon, Tue, Wed, Thur, Fri	12:00 - 18:59 Ivl.:2 Mon, Tue, Wed, Thur, Fri	09:00 - 11:59 Ivl.:4 Mon, Tue, Wed, Thur, Fri	10:00 - 11:59 Ivl.:4 Mon, Tue, Wed, Thur, Fri	11:00 - 13:59 Ivl.:2 Mon, Tue, Wed, Thur, Fri
17:00 - 18:59 Ivl.:3 Mon, Tue, Wed, Thur, Fri	19:00 - 21:59 Mon, Tue, Wed, Thur, Fri	12:00 - 17:59 Ivl.:2 Mon, Tue, Wed, Thur, Fri	12:00 - 13:59 Ivl.:1 Mon, Tue, Wed, Thur, Fri	14:00 - 21:59 Ivl.:1 Mon, Tue, Wed, Thur, Fri
19:00 - 20:59 Ivl.:1 Mon, Tue, Wed, Thur, Fri	22:00 - 23:59 Ivl.:1 Mon, Tue, Wed, Thur, Fri	18:00 - 22:59 Ivl.:1 Mon, Tue, Wed, Thur, Fri	14:00 - 15:59 Ivl.:4 Mon, Tue, Wed, Thur, Fri	22:00 - 23:59 Ivl.:2 Mon, Tue, Wed, Thur, Fri
21:00 - 23:59 Mon, Tue, Wed, Thur, Fri	00:00 - 11:59 Ivl.:1 Sat, Sun	23:00 - 23:59 Ivl.:3 Mon, Tue, Wed, Thur, Fri	16:00 - 22:59 Ivl.:1 Mon, Tue, Wed, Thur, Fri	00:00 - 13:59 Ivl.:2 Sat, Sun
00:00 - 00:59 Sat, Sun	12:00 - 19:59 Ivl.:2 Sat, Sun	00:00 - 07:59 Ivl.:3 Sat, Sun	23:00 - 23:59 Ivl.:3 Mon, Tue, Wed, Thur, Fri	00:00 - 13:59 Ivl.:1 Sat, Sun
01:00 - 11:59 Ivl.:1 Sat, Sun	20:00 - 22:59 Sat, Sun	08:00 - 11:59 Ivl.:1 Sat, Sun	00:00 - 05:59 Ivl.:3 Sat, Sun	Holiday 00:00 - 07:59 Ivl.:1 Mon, Tue, Wed, Thur, Fri, Sat, Sun
12:00 - 13:59 Ivl.:3 Sat, Sun	23:00 - 23:59 Ivl.:1 Sat, Sun	12:00 - 17:59 Ivl.:2 Sat, Sun	06:00 - 13:59 Ivl.:1 Sat, Sun	08:00 - 09:59 Ivl.:4 Mon, Tue, Wed, Thur, Fri, Sat, Sun
14:00 - 16:59 Ivl.:2 Sat, Sun		18:00 - 23:59 Ivl.:1 Sat, Sun	14:00 - 15:59 Ivl.:3 Sat, Sun	10:00 - 19:59 Ivl.:1 Mon, Tue, Wed, Thur, Fri, Sat, Sun
17:00 - 18:59 Ivl.:3 Sat, Sun			16:00 - 22:59 Ivl.:1 Sat, Sun	20:00 - 21:59 Mon, Tue, Wed, Thur, Fri, Sat, Sun
19:00 - 21:59 Ivl.:1 Sat, Sun			23:00 - 23:59 Ivl.:3 Sat, Sun	22:00 - 23:59 Ivl.:1 Mon, Tue, Wed, Thur, Fri, Sat, Sun
22:00 - 23:59 Sat, Sun				

Automatic Profiles

These are special ventilation profiles that require an indoor and an outdoor humidity/temperature sensor, these sensors allow the profiles to respond automatically to indoor and outdoor conditions and deliver the best air for your space choosing the appropriate mode and speed. When these sensors are used for humidity control it is called dew point control.

Dew point control considers the absolute (real) humidity levels and temperatures both indoors and outdoors and calculates the ideal time to remove moisture from inside. Or if there is risk of moisture entering from outside pauses and closes the flap until better conditions are available. Dew point control is used for cellar ventilation with/without heat recovery. Even though it is described as humidity control it relies on having quality air outside, if better air is not available ventilation will turn off. A CO2 sensor would override dew point control if installed.

These profiles are not based on schedules:



Cellar ventilation with heat recovery For operation in heated rooms where heat recovery and temperature and humidity automation are desirable. This mode allows for automatic dew point control.



Cellar ventilation For operation in unheated rooms where temperature

and humidity automation is desirable. This mode allows for automatic dew point control.



Summer operation for automatic summer cooling in hot summer months. This mode is used during the warm season and constantly compares indoor and outdoor temperatures. The system automatically decides whether the indoor climate should be maintained or if “free cooling” should be carried out with the ventilation function. This mode should only be used during the warm seasons where the introduction of cool air from outside is desirable. There is a temperature protection limit of 16°C to avoid introducing too cold air, even in summer.

Control Logic

Units with no optional sensors added. The units run continuously in whatever mode it is set to. Time schedules dictate any changes to mode or speed. No response to temperature or humidity. Default speed is 1 (default setting is at 25%).

Units with a wall controller installed in the home. As for when there are no sensors added.

Units with an indoor temperature and humidity sensor installed in zone. If humidity exceeds the set threshold (default 70%) for zone the heat recovery mode will switch to through mode with fan speed at level 3. The units won't respond to outdoor temperature or humidity without an outdoor sensor.

DVS HIGH PERFORMANCE: RECLAIM MINI USER MANUAL

Units with a CO2 sensor installed in zone. If CO2 levels exceed the set threshold (default 1500PPM) for the zone the heat recovery mode will switch to through mode with fan speed at level 3. The CO2 sensor will also respond to humidity as per the indoor temperature and humidity sensor. The units won't respond to outdoor temperature or humidity without an outdoor sensor.

Units with an indoor sensor in zone and an outdoor sensor for the home. If both sensors are installed then your are able to operate in one of the automated profile modes. If the indoor sensor in the zone is a CO2 sensor then boosts for CO2 will take priority. Dew point control and summer operation are two potential operating functions. See Automatic Profiles for logic description.

occasionally used for feedback on operation of the specific unit. The inner panels connect wirelessly to the rest of the units in the system, if there is no wall controller in the system then one of the inner panels becomes the master and takes charge of the rest of the system.

To access the filter the automatic closure flap must be removed. To do this the unit must be paused, disconnecting the power will not close the flap and will instead lock it open, forcing the flap to close can break the lever or arm. Instead ensure the power is on and use the wall controller or the app to pause operation for the relevant unit or the entire system.

When no wall controller is installed in the system the master also connects via Bluetooth to the app, see Connecting to the App for instructions on how to connect. Bluetooth range is ~5m.

Components

Inner Panel and Filter

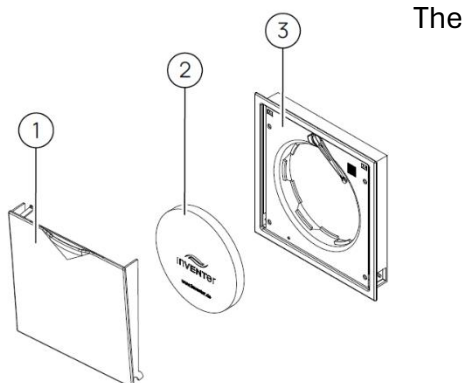

Fig. 3: Structure, Connect inner panel

- 1 Automatic closure flap
- 2 Filter¹⁾
- 3 Electronics cover

inner panel is the main panel you see on the wall. This is where you access your filter, there is also an LED that is

Wall Controller (Optional)

The Reclaim Mini wall controller can be used to observe and control the units. When present in a system it also acts as the go between for the Bluetooth connection to the app. The controller connects wirelessly to the units but is wired for power. Bluetooth range is ~5m.

DVS HIGH PERFORMANCE: RECLAIM MINI USER MANUAL

While up to 16 items can be present in the system and divided up into up to 4 zones the allocation of zones is only possible via the app. Only one wall controller should be installed per home.

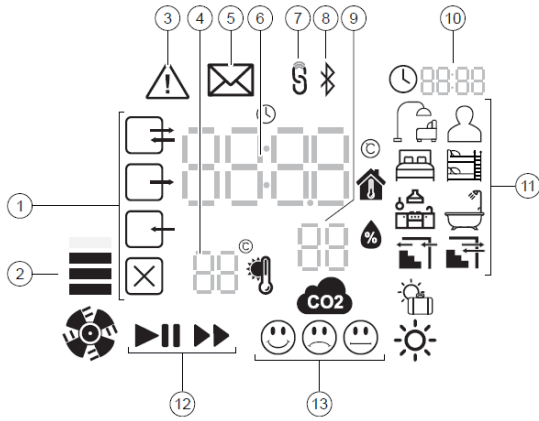

- 11 Ventilation profile display (profile icons)
 - Living room
 - Default profile
 - Bedroom
 - Children's room
 - Kitchen
 - Bathroom
 - Cellar ventilation
 - Cellar ventilation with heat recovery
 - Holiday mode
- 12 Status display
 - Auto = System operating with set ventilation profile
 - Pause = System is paused
 - Boost = System operating with maximum air volume flow
- 13 CO₂ content display
 - = good
 - = high
 - = slightly elevated

- 1 Ventilation mode
 - Heat recovery
 - & Through-ventilation
 - Pause/ventilation off
- 2 Ventilation levels (factory setting)

1	25%	Air Volume Flow	
2	35%		
3	50%		
4	100%		
- 3 Warning/error message (detailed description in the app)
- 4 Ambient temperature display
- 5 App notification
- 6 Display of the time/indoor temperature of the selected ventilation zone (when indoor sensor is installed)
- 7 RF868-MHz radio connection status symbol
- 8 Bluetooth connection status symbol
- 9 Humidity display for the selected ventilation zone (when indoor sensor is installed)
- 10 Display of the current time, alternating with the active ventilation zone

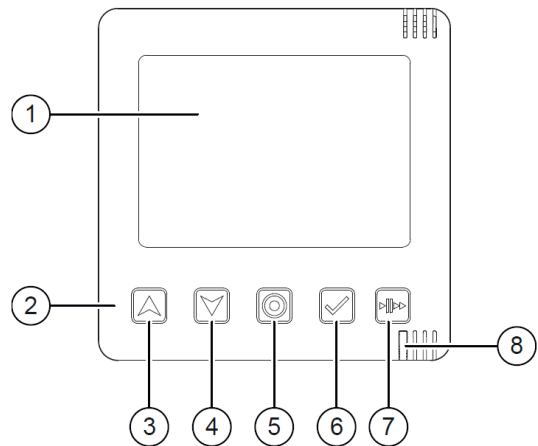

- 1 Display screen
- 2 Control panel (sensor keys)
- 3 Navigation key up/forwards
- 4 Navigation key down/backwards
- 5 Mode key
- 6 Select key
- 7 Auto / Pause / Boost key
- 8 Status display (LED, multi-coloured)

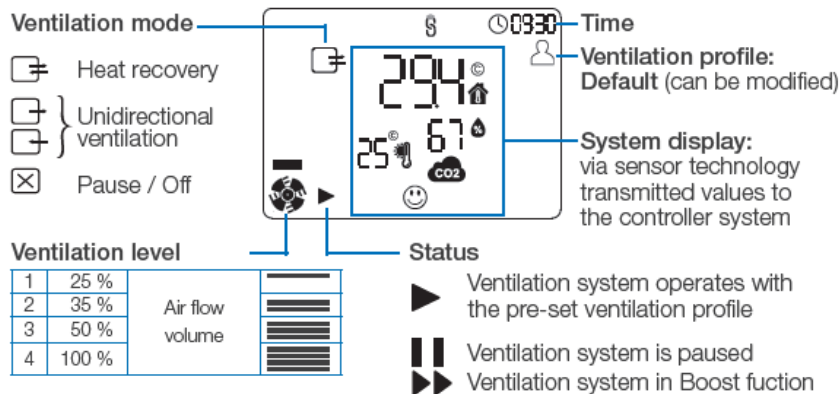

CO2 Sensor including Temperature and Humidity (Optional)



Fig. 1: CO₂-Sensor CS2-Connect

- 1 Housing with sensor electronics
- 2 LED (multicoloured)
- 3 Button

Designed for monitoring of CO₂ (Carbon Dioxide) concentrations in the specific zone. It also monitors temperature and humidity and can take the place of needing an indoor temperature and humidity sensor in a specific zone as well. CO₂ takes priority in the zone it is installed in, always

CO₂ is produced when we exhale as a natural byproduct of our metabolism. It's not the only thing we produce when we live and breathe in a space but it's particularly good as a measure of occupancy. The CO₂ sensor is triggered by settable thresholds. The default setting is 1500PPM, you can adjust as required.

This sensor is wired for power but communicates wirelessly. The sensor should be placed in a space where the highest occupancy is expected.

Temperature and Humidity Sensor (Wireless)

While the Reclaim Mini is a continuous ventilation solution designed to run all the time sometimes the conditions require a little extra sensitivity. If we're bringing air in from outside but it's a foggy misty morning, or any time then the additional humidity sensing might make a world of difference.

These sensors are battery powered and communicate wirelessly as well. The sensors should be accessible so the batteries can be replaced. Battery type AAA or MN2400.

Indoor



Fig. 2: FTS19-Connect Indoor humidity/temperature sensor

- 1 Housing with sensor electronics
- 2 Button (bottom of housing)
- 3 LED (multicoloured)

Indoor temperature and humidity are required per zone that you want dew point control in, although if a zone already has a CO₂ sensor then an additional sensor is not required. The more sensors the better your systems knowledge of your inside space is. It uses this to determine the best ventilation settings for each unit (speed and direction).

Outdoor

Only one outdoor sensor is required for a home, it connects to Zone “0” and all indoor sensors in their individual zones will compare to these outdoor conditions. Any time an indoor sensor is being used an outdoor sensor should also be installed.

The outdoor sensor’s best placement is under shelter out of direct weather and sun; this allows it to be reflect the ambient conditions rather than be impacted by isolated solar or wind impacts.



Fig. 3: FTS19-Connect Outdoor humidity/temperature senso

- 1 LED (multicoloured) (in housing)
- 2 Button (in housing)
- 3 Housing with sensor electronics

Programming Your System

All control options are available on the app; most are available on the wall controller however the app is required for customised commissioning options.

Note: *It is best that the main user be available with a mobile device when the system is getting installed as it is necessary for safe operation of the closure flap to have a control connected. Otherwise a wall controller is recommended.*

Connecting to the App

First time

Download the IEQ Guardian App to your mobile device using Google Play or the Apple App store.



I.E.Q. Guardian

Before attempting to connect for the first time enable Bluetooth and location on your phone.

Put your Reclaim Mini into pairing mode – this is done at the master. If a wall controller is present this is the master, if not wall controller is present then the main inner panel is the master, this should be set at the time of install. See below for Bluetooth pairing.

When your master is in Bluetooth pairing mode press connect on your mobile device. A message will appear when pairing is complete and you will be able to select “Complete setup”, choose

DVS HIGH PERFORMANCE: RECLAIM MINI USER MANUAL

a name or leave as default and press “OK”.

The device name should now appear in the window. A blue Bluetooth icon indicates that your phone can sense the unit nearby. Bluetooth should not need to be turned on on the unit again for reconnecting to the same mobile device.

Bluetooth Pairing Modes:

Wall Controller On the wall controller hold down the *Mode Key*  until the **light flashes blue**.

Inner Panel On the inner panel ensure that the flap is removed and insert a push tool (eg. small screwdriver) into the hole on the bottom left, hold down until **LED turns blue**.

Note: to access the button inside the inner panel you will need a previously connected control device to pause or power off the unit, alternatively you may wait for the flap to close itself. Take caution as you can break the flap catch if forced.

When App has been Connected Before



Your master device should appear in the apps main screen. A **blue** Bluetooth icon indicates that the device is within range and available. If the Bluetooth icon is greyed out or if the app is not loading your system try cycling power to the system and fully closing the app on your phone. You should not need to put the unit back into Bluetooth mode.

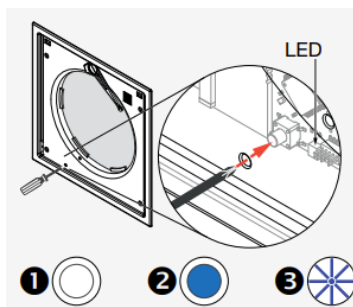

Recommended Set-Up

1. Decide how many zones you need and allocate devices to zones (you determine number of zones by areas in your home requiring different schedules – one zone might be okay). You'll also need to consider which sensors to use in each zone, as they can help improve comfort, sensors in bedroom zones are recommended.
2. Allocate a ventilation profile to each zone, this should reflect how you use the zone.
3. Consider the fan speeds. If you are wanting to reduce moisture you may wish to increase speed 3 to 100% (speed 4 is only used for purge). If comfort and efficiency are more important then lower speeds should be used.
4. Allow the system to run on it's own, boosting only when required (after particularly cold nights when misting may occur, or when there are lots of guests or if there has been an activity that generates high contaminants and you'd like to purge them)
5. Remain aware of your moisture producing activities and placement of items that may contain moisture or be damp (washing, towels, rain coats) and take measures to dry these in appropriate spaces (laundries or bathrooms with extraction if they must be inside, outside is best).
6. Keep the house at a healthy temperature, we recommended temperatures over 20 degrees (although you may find 18 degrees sufficient) in cold seasons and under 26 degrees in warm seasons (utilise summer mode as appropriate and turn off before winter).

On the App

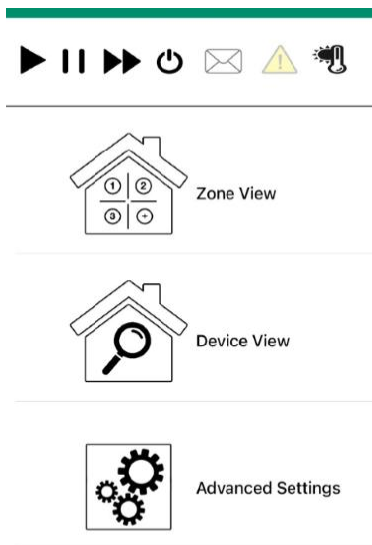

Figure 2 Main menu

Main Menu

Open the app and select your device to navigate to the main menu:

The navigation bar appears across the top of the screen with the following icons:





Selecting an icon will either activate that mode for the whole system or open an information screen.

 Auto symbol: Automatic operation according to the ventilation profile setting, normal mode.

 Pause symbol: Quick selection of pause for the system

 Boost symbol: Quick selection of boost for the system

 Power symbol: Quick ON/OFF for the system

 Message symbol: System notifications

 Warning symbol: Display of error messages

 Ambient conditions: Outdoor sensor readings, only displays if there is one.

This menu is also where you access the following main areas: **Zone view**, **Device View** and **Advanced settings**.

Zone View

Allows you to view all the ventilation zones. You can swipe to navigate between the four zones available. By default all components are assigned to zone 1. This view is also where you can change the zone ventilation profile, override speed or ventilation mode (for the set period of time) and set the humidity and CO2 limits for a zone.

Advanced Settings

Provides access to more detailed programming, performance and device data. Particularly useful settings are:

System update always perform an update when you first access the app.

Ventilation profile manager to reprogramme profiles schedules.

Ventilation levels for speed level settings (1,2,3,4)

DVS HIGH PERFORMANCE: RECLAIM MINI USER MANUAL

Device View

Allows you to view all paired devices, their signal strength, dominant direction and zone; and for sensors, if connected, their readings. You can also change ventilation zone, identify where a component is in the house, choose a repeater (if option available) and access

more detailed settings for individual units.

The below are the typical icons that might be displayed. You can rename devices by selecting the device and going to the device page (see next page).



Example screen:
All paired devices active





Sym- bol	Status	Paired component
	-	Controller
		Fan with supply air direction of rotation
		Fan with direction of rotation exhaust air
		CO ₂ content Good
		CO ₂ content Slightly raised
		CO ₂ content Too high
		Switching contact active
		Switching contact triggered
	25,4°C 22,1%	Transmitted temperature
		Transmitted humidity
	25,4°C 22,1%	Transmitted temperature
		Transmitted humidity

The following displays are possible in the Availability area:

- Green colour : a component is integrated in the system and active
- Yellow colour : a connected component is not accessible due to an error

DVS HIGH PERFORMANCE: RECLAIM MINI USER MANUAL

Other symbols

Symbol	Status
	Strength of the radio signal currently present.
	"Radio signal weak": A signal amplifier is recommended for the paired device (see Section 6.10 "Setting a device as a signal amplifier (repeater function)" on page 107).
	Device acts as a signal amplifier (repeater) for another device in the system
	Device identification

Identifying the Device

In the Device View, on a specific device selecting the *Magnifying Glass*  shown at 5 in Figure 3 below will flash the LED on the corresponding component **purple** and **yellow**.

Changing Device Zone

In Device View screen click on the Ventilation Zone (item 6 in Figure 4), a drop-down menu will appear, select your preferred zone from this menu.

Your new zone should be displayed.

Note: wall controllers and master units are always zone one, outdoor sensors always service all zones.

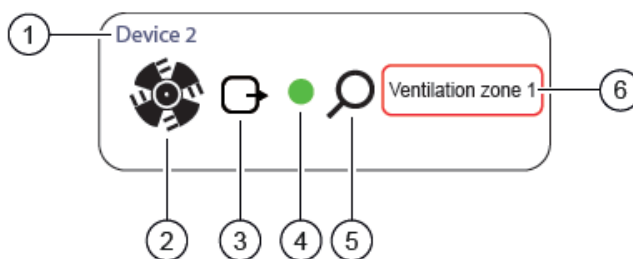

- 1 Device name (initially "Device"; this can be changed later)
- 2 Device symbol
- 3 Device status
- 4 Availability
- 5 Device identification
- 6 Allocated ventilation zone (text in black if the ventilation zone can be changed, grey if the ventilation zone is specified by the system)

Figure 3 Device overview in device view

DVS HIGH PERFORMANCE: RECLAIM MINI USER MANUAL

Changing Device Name

In Device View select the device you'd like to rename.

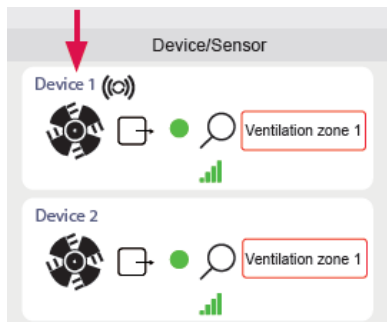

Figure 4 In Device View select the device

That will open the device screen, where the option to “Edit device name” will be showing.

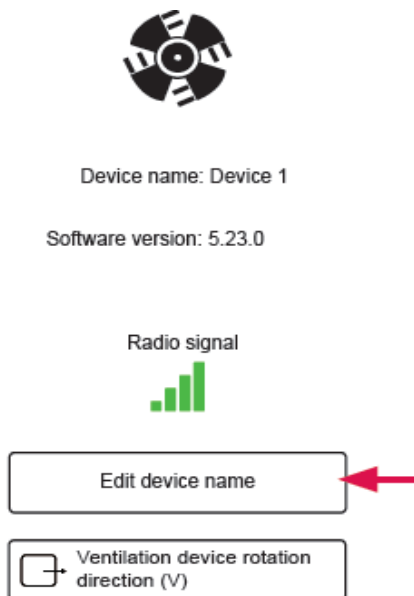

Figure 5 On device screen select edit device name.

Selecting this will open a window to edit the name, you may cancel before saving if you wish. “OK” to save.



Changing Device Direction

Also, in the device screen opened from the “Device View”, same as for *Changing a Device Name*, you will see “Ventilation device rotation direction”.



Device name: Device 1

Software version: 5.23.0

Radio signal

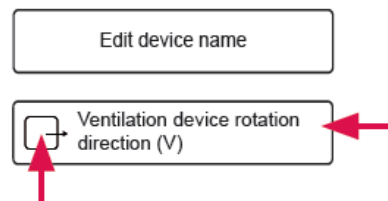

This will show you both the dominant device direction (in or out of the home) and allow you to change it by clicking anywhere on the button – observe the arrow changing direction. For a balanced home aim to have 50% of devices in the zone in Supply and 50% dominant for extract.

In *Through Mode* it may seem more comfortable to have bedrooms as extracts and living spaces as supplies (air enters at the living and exits at the bedroom) but for better performance (if the outside air is of a high quality) having the bedroom as a supply may be better. Try both to see if there is a noticeable performance difference.

Note: bedrooms with ensembles should exercise caution when using Extract.

Setting Up Zones

All components are assigned to zone 1 by default. You can group components in up to 4 zones.

To allocate a unit or sensor to a zone:

1. Press “Device View” to see all devices.

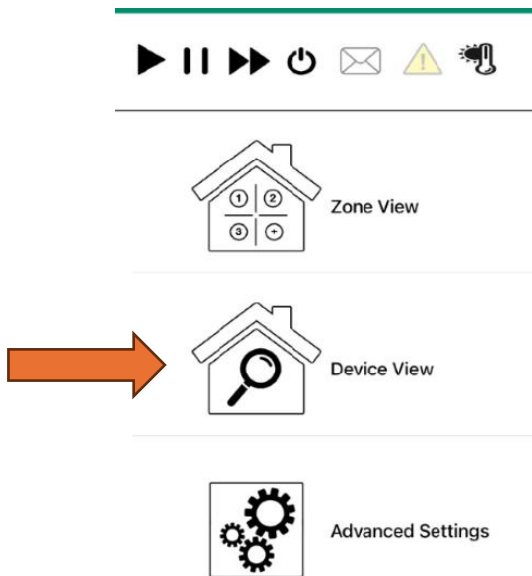

2. The “ventilation zone” will be displayed on the right (see second image below), pressing on this will allow you to choose a new zone. From the drop down list that appears in Figure 6.

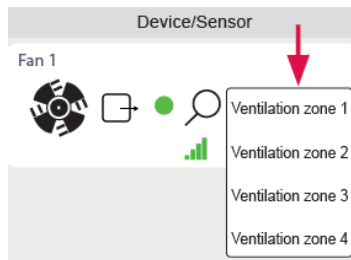
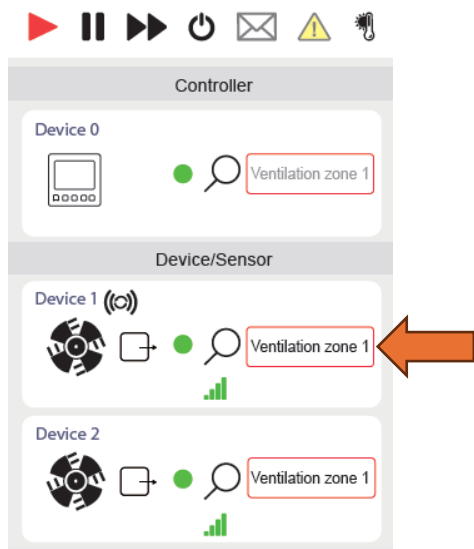

Figure 6 Zone drop down.

You should group similar rooms together. If you’re happy with the same schedule for the whole house leave them all on zone 1. The master panel / wall controller and outdoor sensor (depending on what’s installed) must always be in zone 1 and can’t be changed.

Defining Zone Profiles

Back in the Main Menu (see Figure 2 as a reminder) go to *Zone View*.

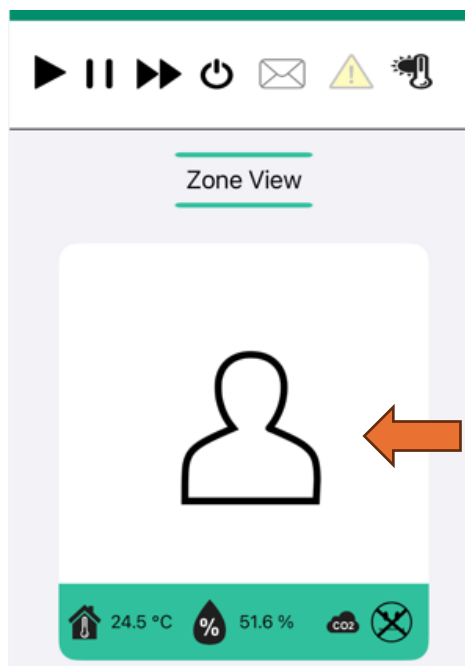

Figure 7 Zone tile, swipe for more or select to open and programme.

If there are multiple zones you will be able to swipe in this screen to view them all. The window quickly covers the

DVS HIGH PERFORMANCE: RECLAIM MINI USER MANUAL



Figure 8 Swiping through zones in zone overview

current zone temperature, humidity and CO2 acceptability.

By selecting the zone tile (Figure 7) you will access that zones programming screen.

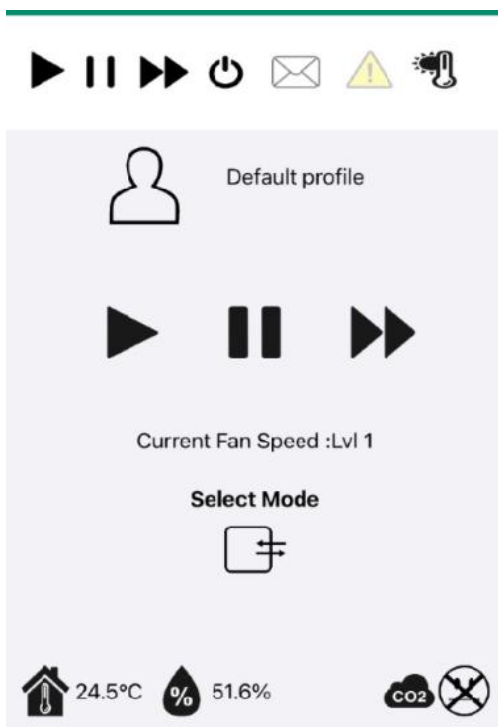

Figure 9 Zone programming screen

Here you can set the profile (*Scheduled* or *Automatic*), mode (*Heat Recovery* or *Through*), change the zone humidity and CO2 limits, name the zone and override the current profile.

Changing the Zone Name

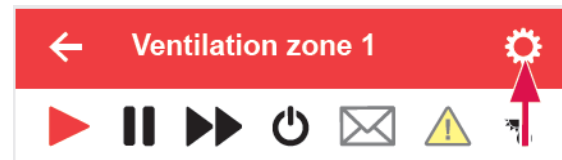

Figure 10 Zone settings cog

Select the settings cog in the top right. This will open a drop-down menu in Figure 11, where the option for naming the ventilation zone is shown.

Changing Humidity and CO2 Limits

From the same settings cog as shown in Figure 10 the drop-down menu will also allow you access to Ambient Humidity and CO2 limit settings.

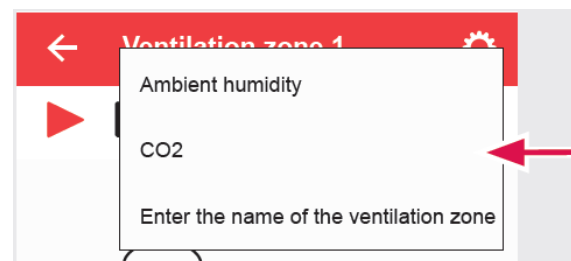

Figure 11 Zone settings drop down menu

DVS HIGH PERFORMANCE: RECLAIM MINI USER MANUAL

Humidity Limits

Humidity limits set here trigger an automatic response when a temperature or humidity sensor is installed inside. The trigger occurs when humidity inside the home exceeds the set limit. When this occurs, the speed will boost to level 3 and switch to *Through Mode* regardless of schedule.

Decrease the limit to move more air and (if the outside air quality is good) help reduce moisture inside.

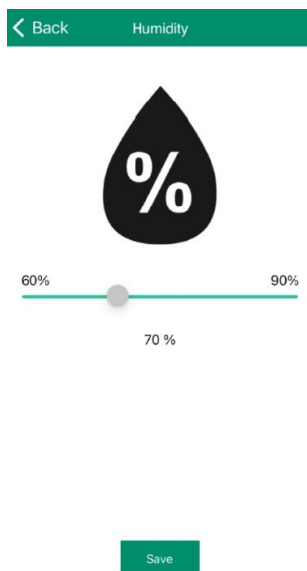

Figure 12 Zone humidity limit screen

CO2 Limits

The CO2 limit dictates when the zone will boost due to poor indoor air quality. When the CO2 reading exceeds the limit. When this happens the system switches to speed 3 and into *Through Mode*. This takes priority over any scheduled operation.

Recommended setting: 1000PPM

Minimum setting: 1500PPM

For more ventilation decrease the limit. If the sensor is outside of a highly

occupied zone you may choose to go to the lowest setting for more ventilation.

Note: Human mental and physical performance is best at levels below 1000, however CO2 alone is unlikely to reach an unsafe level. Too much ventilation unnecessarily can decrease the comfort of the home.

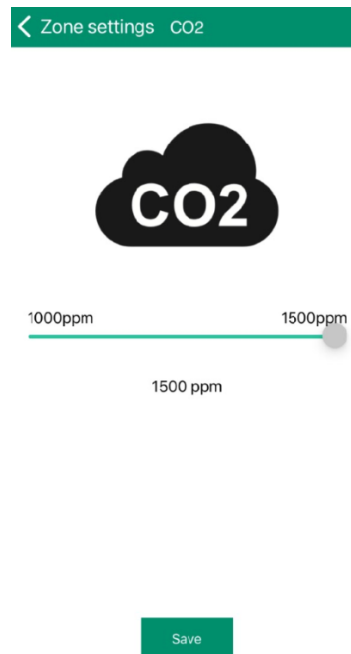

Figure 13 Zone CO2 limit setting

Setting Zone Profile

In the *Zone programming* screen (Figure 9) you can set the zone profile.

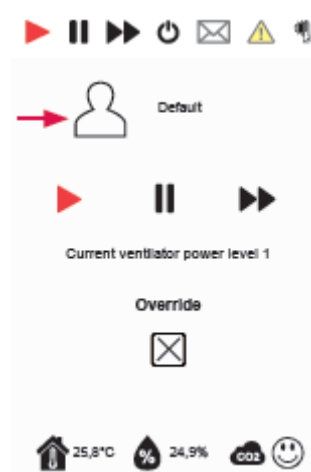

Figure 14 Zone programming screen select profile

DVS HIGH PERFORMANCE: RECLAIM MINI USER MANUAL

Select the current zone profile to open a zone menu. The available profiles will be shown; you may need to scroll down for more.

Pressing a profile will select it and return to the programming screen with new image.

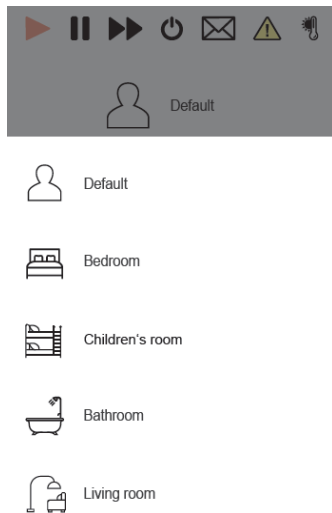

Figure 15 Zone profile options available for zone.

You can find the default schedules associated with each *Scheduled Profile* in Figure 1 on page 5 and the profile descriptions on pages 4-on page 6.

If a profile is used across multiple zones the schedule for each using that profile will be the same. You can change the default schedule though.

Scheduling

Changing of profiles schedule is done in the Advanced Settings.

Boosting and Pausing

Pause To activate pause mode for the ventilation zone, press the Pause button in the active window.

- ▶ Pause mode is selected. The pause symbol is displayed in red.

- ▶ A countdown appears on the screen to show how long the ventilation zone is still in pause mode.

Boost To activate boost mode for the ventilation zone, press the Boost button in the active window.

- ▶ Boost mode is selected.

- ▶ Ventilation level 4 is set.



- ▶ The boost symbol is displayed in red.

- ▶ A countdown appears on the screen to show how long the ventilation zone is still in boost mode.

Wall Controller

When using the controller, the first screen on waking always shows the information for zone 1. To change a setting in a zone you must be in the right zone screen. If only one zone is in use (default is only zone 1) then you can undertake all controls from the initial screen.

Zone Navigation

To navigate between zones on the wall controller press the *Mode Button* , followed by the *Up Arrow* , until you see the desired zone, press the *Select Key*  to display the data for the selected zone. The number of the zone being displayed will flash in the top right corner, alternating with the time.

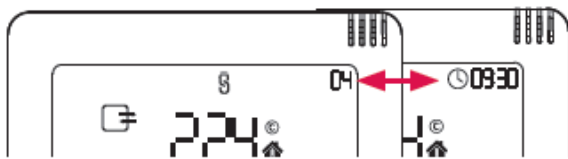







Figure 17 Zone on display will be shown top right, alternating with time.

Setting Zone Fan Speed, Ventilation Mode and Zone Profile

When you are in the right zone screen (refer Zone Navigation), switching between the setting options is done by pressing the *Select Key* . Pressing *Select*  multiple times will navigate between settings options as shown in Figure 16 below.

When a setting is flashing in the right sector the *Arrow Keys*  will allow you to change between settings. To exit press the *Mode Key* . What ever icon was flashing when you press mode will become the active setting. To change multiple settings at once press *Select*  once your preferred option is active to cycle between sectors and only press *Mode*  once you have completed all settings.

Note: A changed fan speed or ventilation mode is only active for a set time period (default is 1 hour, changeable via the app) before returning to the profiles programmed settings.

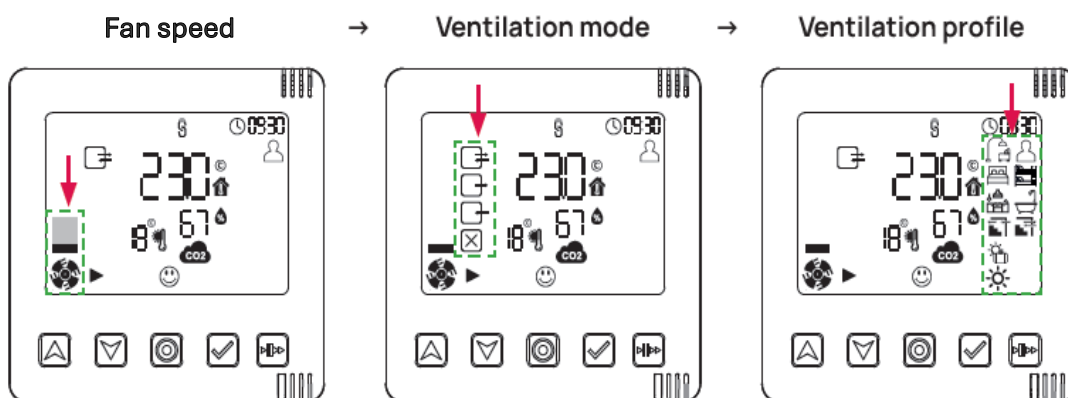





Figure 16 Setting sectors

DVS HIGH PERFORMANCE: RECLAIM MINI
USER MANUAL

Pause and Boost

From your desired zone (zone number should alternately flash with the time in the top right) or, for **all** zones, from the main screen press the *Boost/Pause Key*  until your desired function is flashing.

Note: To set only zone 1 navigate to zone 1 by pressing *Mode* , when 01 is flashing in the top right press the *Select Key* . The number for the zone should then be alternating with the time, proceed as below.

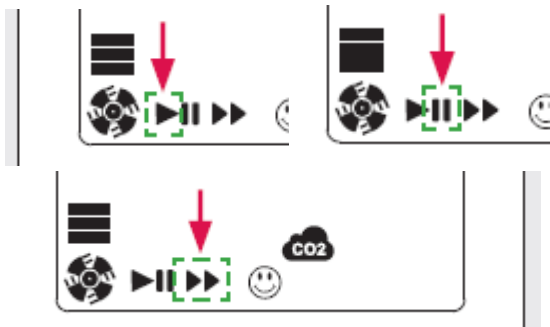



Figure 18 Normal, Pause and Boost modes

A timer will appear in the centre of the screen above the flashing Boost/Pause icon. With the desired icon flashing use the *Up/Down Arrow Keys*   to set the desired time for the zone/system to remain Boost/Paused.

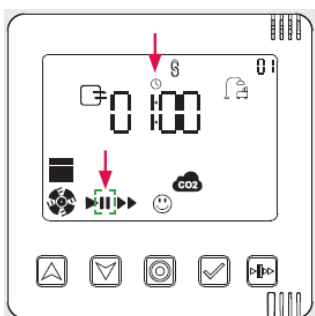

Figure 19 Example of timer over flashing pause button for setting countdown.

Note: The remaining time for the boost/pause function will alternate in the middle of the screen with other zone readings.

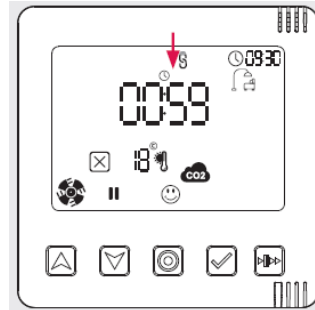

Figure 20 Example remaining time for pause, alternates with zone readings.



Troubleshooting

Inner Panel Lights

Table 3: Status LED display for paired devices, Connect inner panel

LED colour	LED state	Controller status
TURQUOISE	Illuminated	Device not paired
GREEN	Flashing	Devices are being paired
GREEN	Illuminated	Device pairing complete

Wall Controller Events

From time to time the wall controller will inform you of events or errors that have occurred. If a “message”  symbol appears then you must use the app to read the message. The message  symbol will continue to be displayed until cleared or resolved.

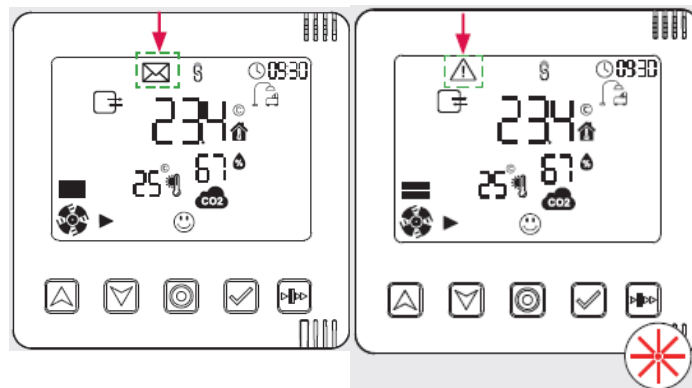







Figure 21 Left Message symbol on wall controller screen. Right Warning triangle and flashing Red LED.

If an error occurs a warning triangle  will be displayed. If the warning triangle  displays and the **Red LED** is flashing it is possible to read the error from the wall controller. **Warning!** This can only be done once, pressing *Select*  will display the error code, press *Select*  again to see if multiple errors exist. If only one code displays despite multiple presses, then there is only one error. Pressing *Mode*  will exit the error screen and stop the light flashing. The warning triangle  will remain displayed until the error is resolved.

DVS HIGH PERFORMANCE: RECLAIM MINI USER MANUAL

Notification (✉)	Error (⚠ & LED on the controller flashes red)	
Description	Code	Description
At least one ventilation device/sensor is switched off	F 01	Time and date on the controller not set or not confirmed
Battery status of the Indoor/Outdoor sensors is low (< 20 %)	F 02	At least one ventilation device/sensor is no longer reachable
Rel. room humidity limit value exceeded	F 03	Firmware update failed
Limit value for CO ₂ content of indoor air exceeded	F 04	Battery status of the Indoor/Outdoor humidity/temperature sensors is low (< 10 %)
Filter change due soon	F 05	Switching contact triggered or switching contact is out of operation
System cleaning due soon	F 06	Filter change required
	F 07	System must be cleaned

Resetting

Resetting controllers, units and sensors should only be done if necessary and advised by DVS. If required, an instruction list for resetting will be supplied. Resetting can accidentally be triggered, if the **LED flashes red** after you have held down any buttons then **do not press anything** until the red flashing light goes away. If it is flashing red and you have not pressed any buttons or it has been flashing for more than 5 minutes then a warning has been triggered, refer to Wall Controller Events for instructions.

If you believe you have accidentally reset your system please get in touch with DVS as you will need to be informed how to reprogramme your system.